

Specification of: DDMP 9/7 M6A0 DA5 230V-1F

High performance centrifugal fan DDMP

Double width, double inlet (DWDI), direct drive, forward curved blades fan. Lap-jointed scroll made of galvanized steel (EN 10142), assembled through a high-technology roller-locked seaming. Straight cut off plate at fan discharge. Impeller with forward curved blades of galvanized steel plate, directly mounted on a brushless, permanent magnets, external rotor motor, without transmission losses, dynamically balanced according to DIN ISO 21940-11. The driver is a separate unit, connected to the fan motor, to power supply and to the control system with quick-connection plugs, ready for operation, without further configuration. Driver directly installed on the scroll, and factory-configured, for a plug and play solution: no further configuration is needed. Continuous speed control of the Drive System by 0 ... 10 V analogue signal, or with Modbus RS485-compliant interface. The complete drive system is in protection class IP 54. Power supply 230V – 50/60 Hz. Air performance ratings according to AMCA 210-07 (Fig. 12) and ISO 5801 (Fig. 69 c and par. 30.2 f).

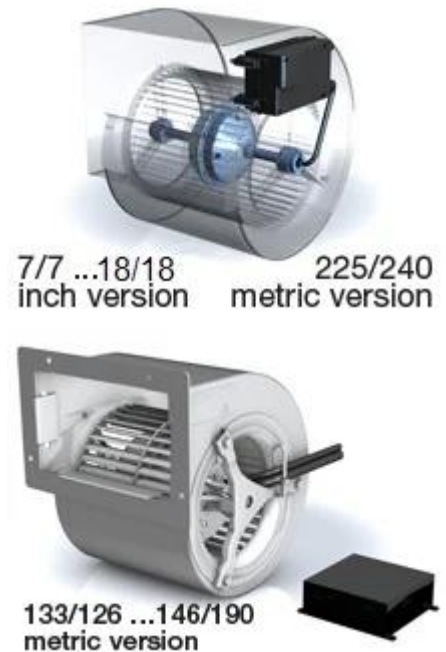

Technical data of the fan: DDMP 9/7 M6A0 DA5 230V-1F

fulfills the ErP requirements 2015

Description	Value Dimension
Specified duty point	
Actual duty point	
Installation acc. DIN 24163 Part 1	B
Reference density (Rho1)	1.20 kg/m ³
Medium temperature (t)	20 C
Fan weight	10 kg
<small>This duty point can only be reached by using an inverter/controller for motor speed control!</small>	
Rated data	
Phases-Voltage-Frequency	1~230-50/60 V-Hz
Rated motor current (I _N)	N/A A
operational limits	
Max. absorbed power (P _{1max})	1.036 kW
Temperature range of conveying medium (t _{min} ...t _{max})	-20...40 C
ErP-Data at best efficiency and density - kg/m³	
measurement- / efficiency category	B / total
design status of VSD	VSD is integrated
overall efficiency (ETA _{opt})	55.8 %
achieved efficiency grade (N _{ist})	62.7
required efficiency grade in 2013 / 2015 (N)	42 / 49
Air flow rate (V _{opt})	1806 m ³ /h
pressure rise (dp _{opt})	826 Pa
Fan speed (n _{vopt})	1998 min ⁻¹
motor power input (P _{1opt})	0.743 kW
specific ratio (d _{dpopt})	1.009

Fan curve to DDMP 9/7 M6A0 DA5 230V-1F

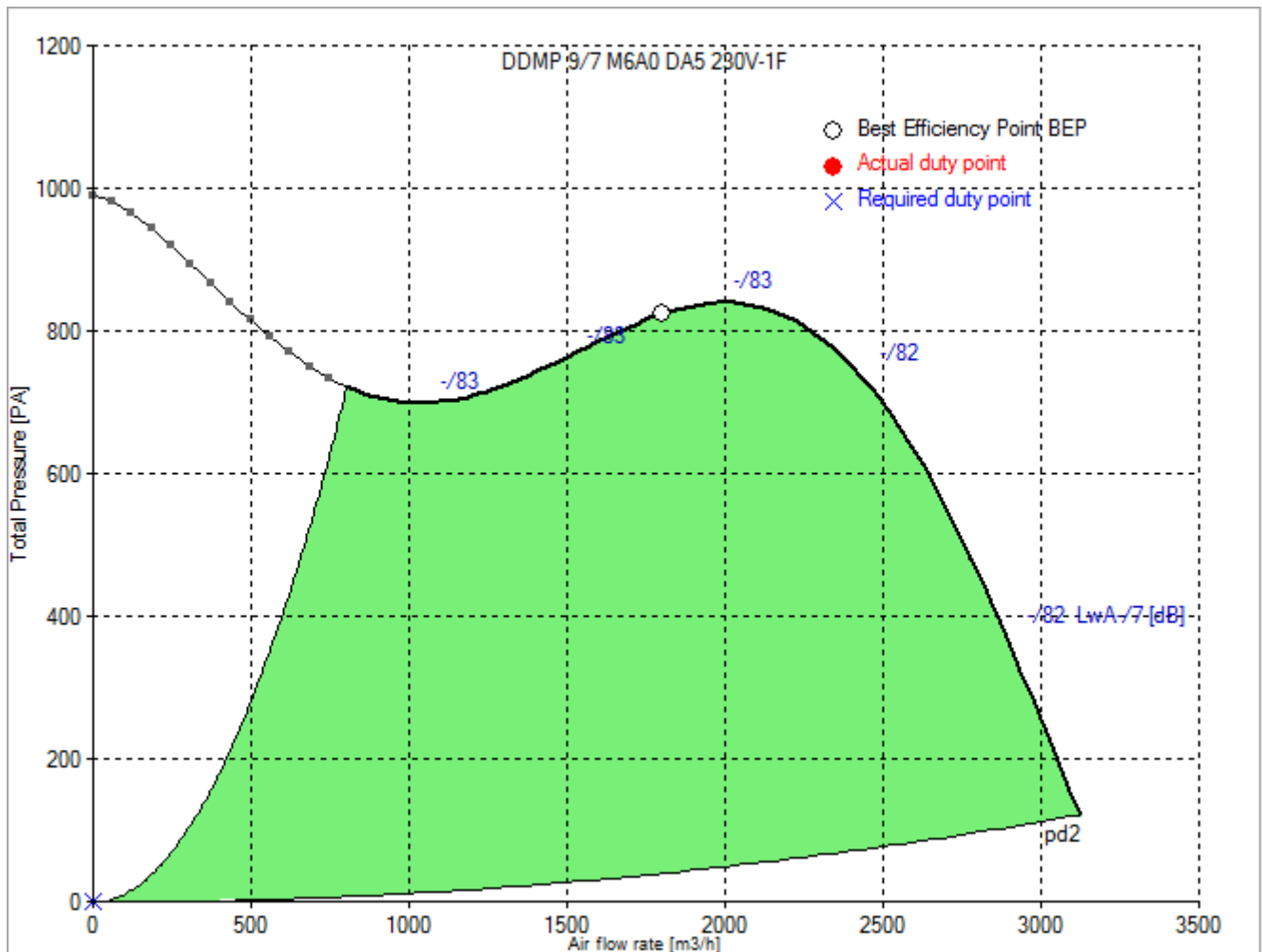

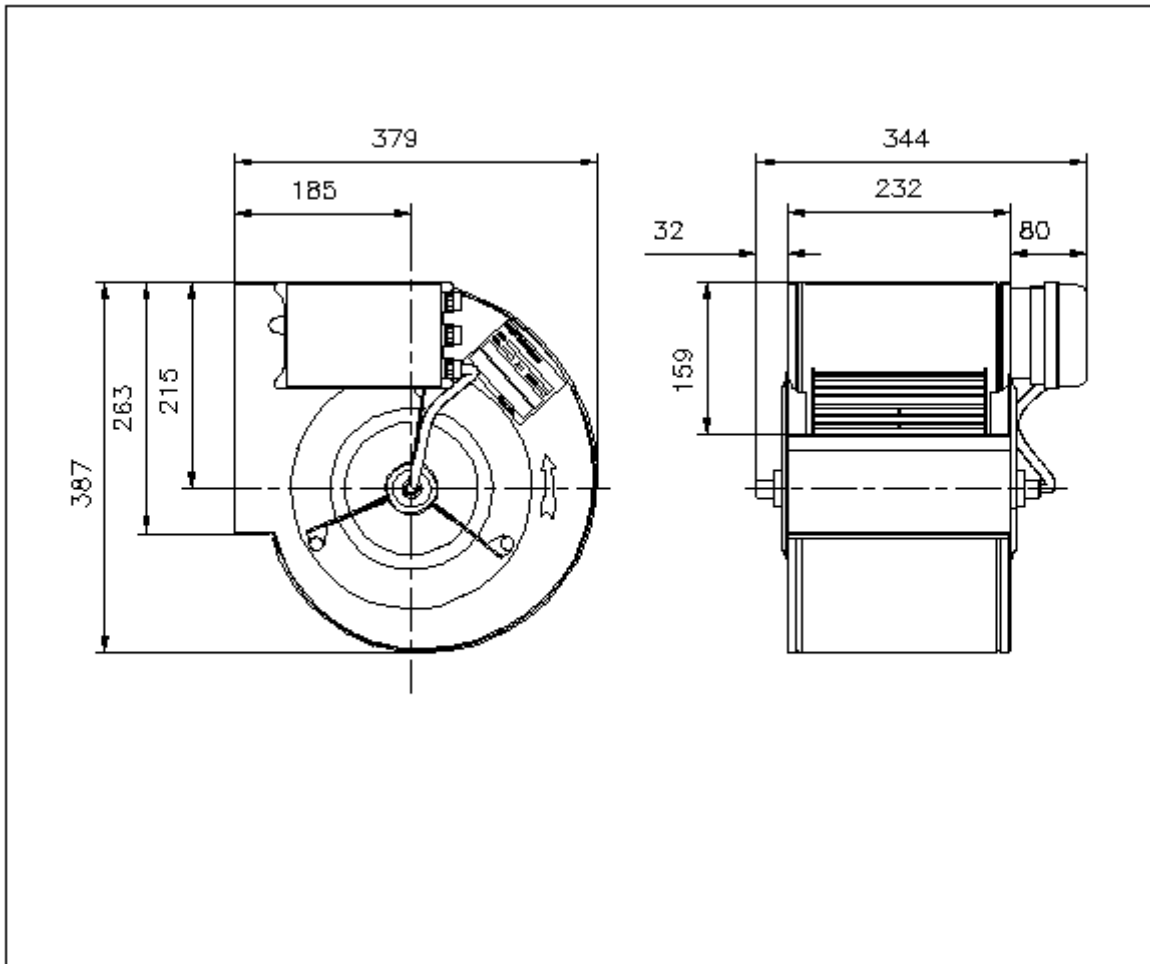

Rotation:
Handing:

RD
90

Wiring diagram of the fan DDMP 9/7 M6A0 DA5 230V-1F

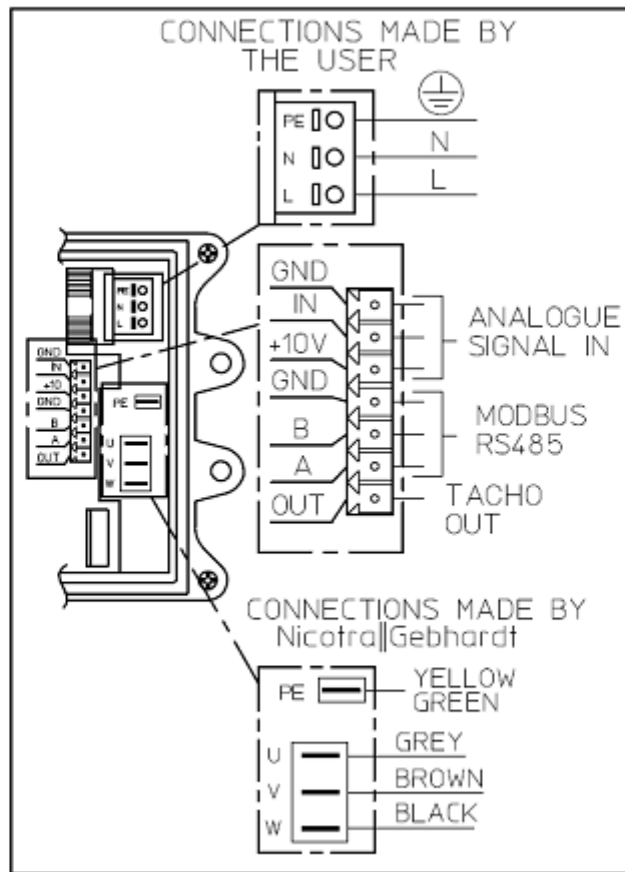

DDMP 1KW

28-11-2017 7W

Wiring diagram for connection to: [mains - VSD - motor](#)
Rotation: [LG](#)